

max. camera cross section:
75x75mm

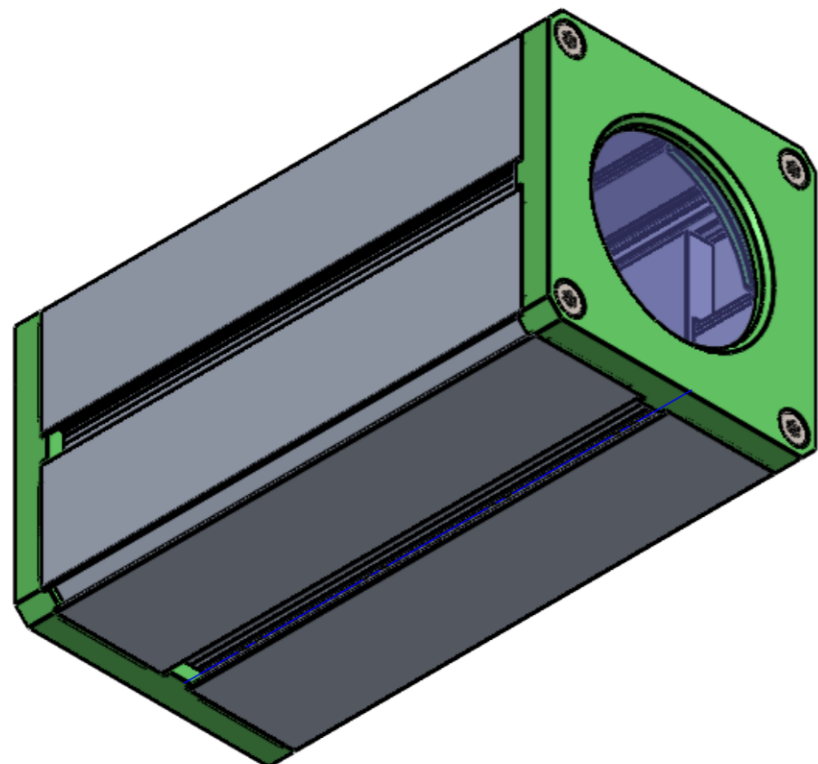
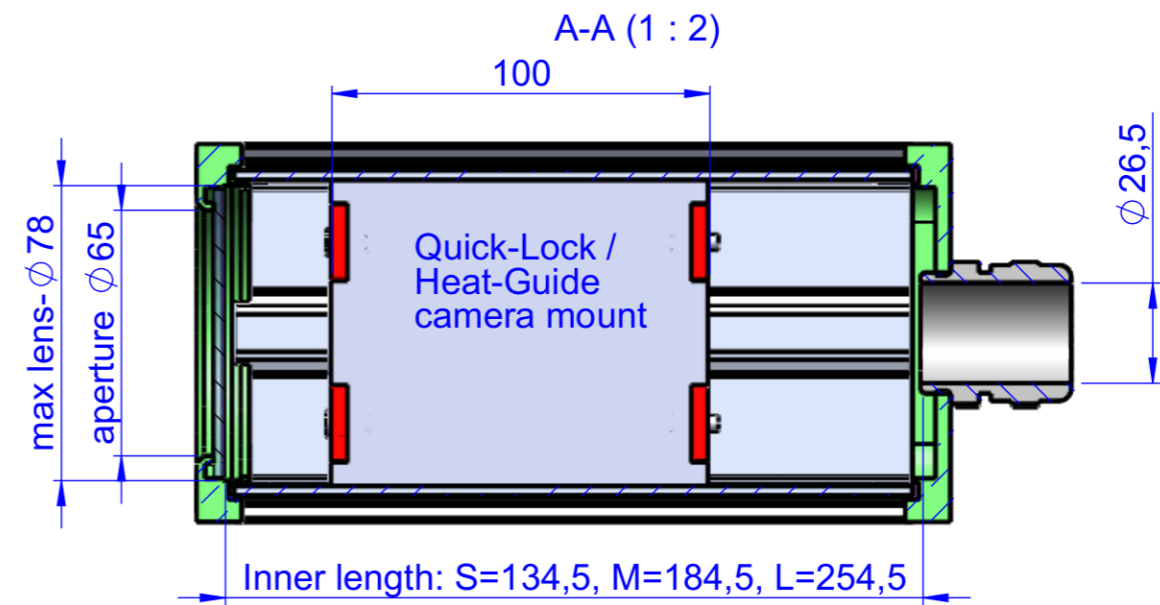
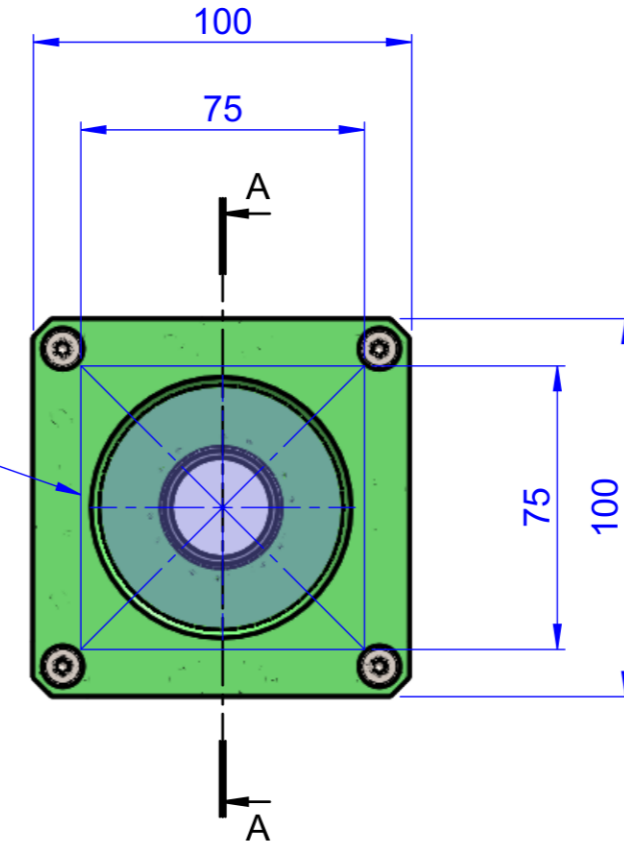

Verwendungsbereich		Allgemeintoleranz DIN ISO 2768-m	Oberfläche	Maßstab: 1:5	Gewicht: 0,00 kg
				Werkstoff: -	
		Datum	Name	Benennung:	
		Bearb. 16.09.2021		Stingray 3" window	
		Gepr.			
		Norm			
				Zeichnungsnummer:	Blatt 1 (A3)
					1 von 1
Zust.	Änderung	Datum	Name		